

VEHICLE PROFILE

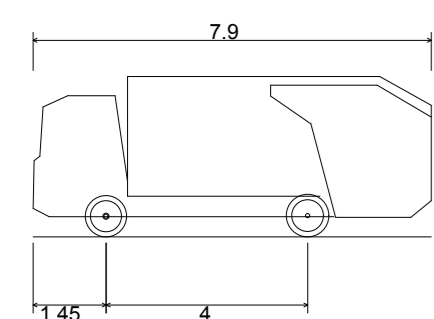

DB32 Refuse Vehicle
 Overall Length 7.900m
 Overall Width 2.400m
 Overall Body Height 3.133m
 Min Body Ground Clearance 0.588m
 Max Track Width 2.400m
 Lock-to-lock time 6.0s
 Curb to Curb Turning Radius 9.625m

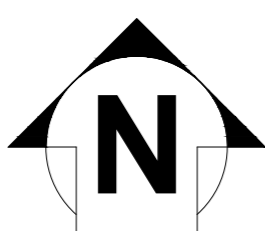

- NOTES**
- THIS DRAWING IS TO BE READ IN CONJUNCTION WITH ALL ENGINEERS & ARCHITECTS DRAWINGS FIGURED DIMENSIONS ONLY (NOT SCALING) TO BE USED. WHERE A CONFLICT OF INFORMATION EXISTS OR IF IN ANY DOUBT - ASK.
 - CONSULTANTS TO BE INFORMED IMMEDIATELY OF ANY DISCREPANCIES BEFORE WORK PROCEEDS.

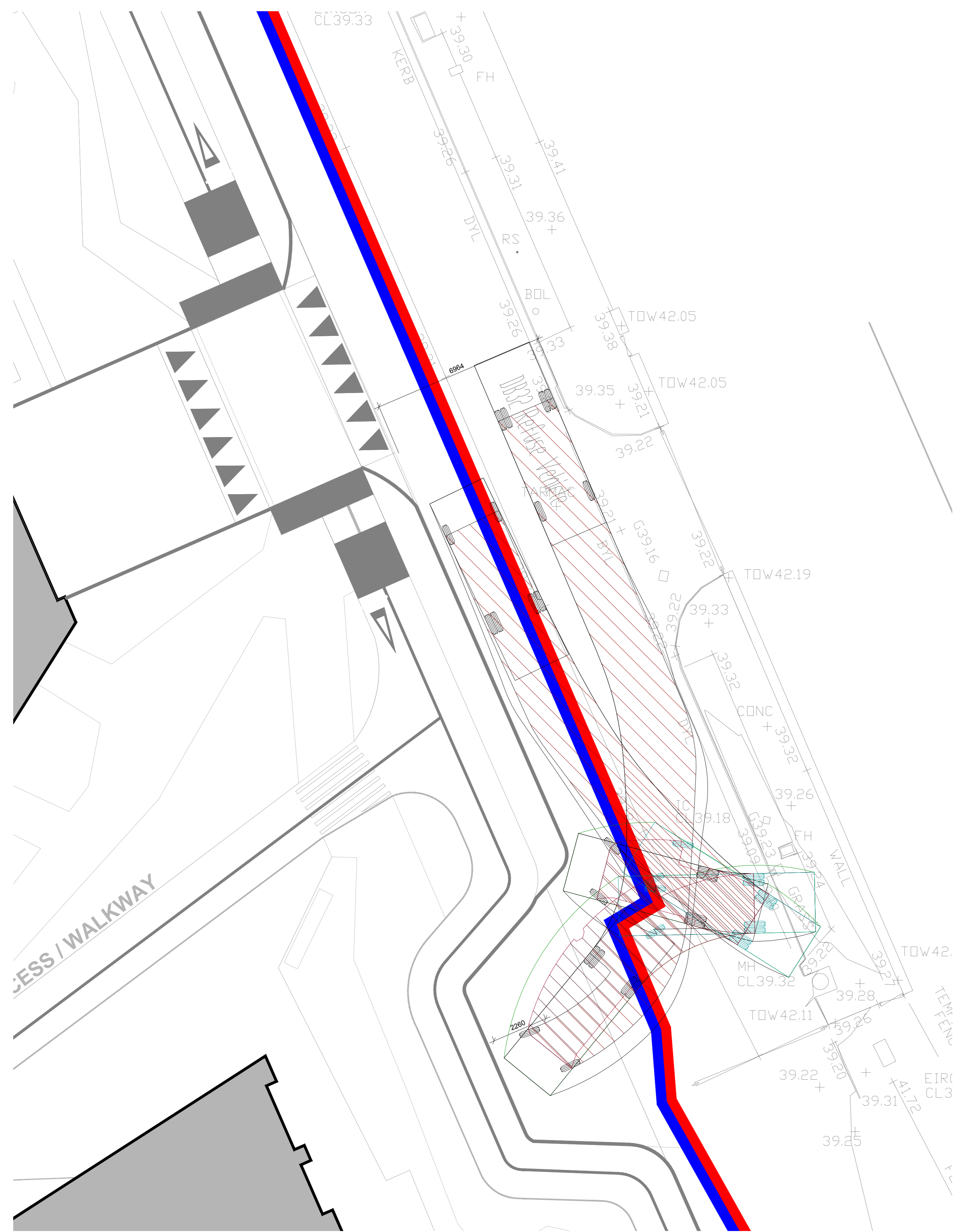

AUTOROUTE REFUSE VEHICLE TRACKING - TURNING

SCALE @ A0: 1:200
 SCALE @ A2: 1:400

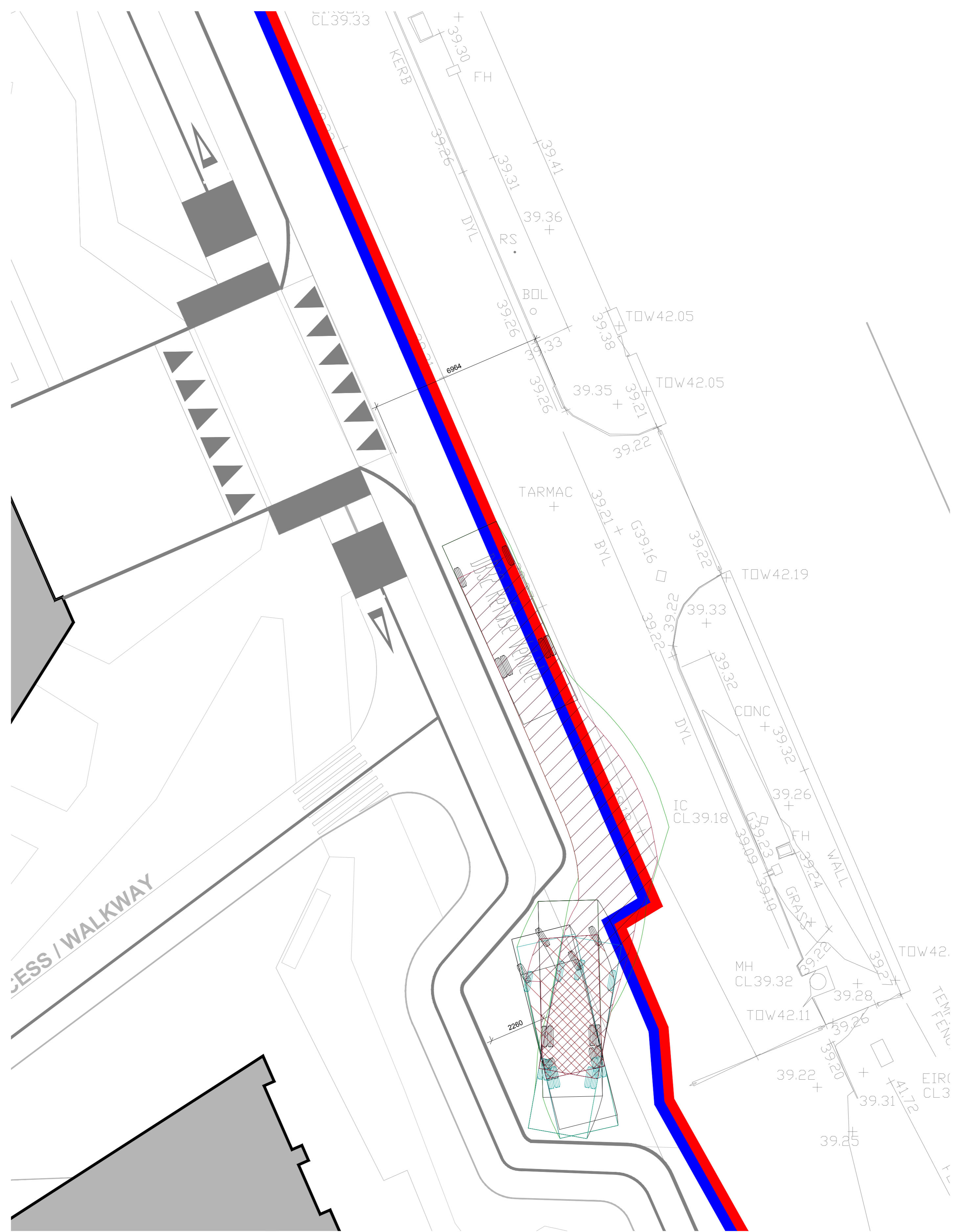

AUTOROUTE REFUSE VEHICLE TRACKING - REVERSE PARKING

SCALE @ A0: 1:200
 SCALE @ A2: 1:400

ISSUE	DATE	DESCRIPTION	DRG	CHK	APP
PL4	18.04.19	ISSUED FOR PLANNING	MS	SP	MS
PL3	18.01.19	ISSUED FOR PLANNING	MS	SP	MS
PL2	07.01.19	DRAFT ISSUED FOR PLANNING	MS	SP	MS
PL1	02.11.18	DRAFT ISSUED FOR PLANNING	MS	SP	MS
P1	23.08.18	ISSUED FOR COMMENT	MS	SP	MS

PLANNING

BM Dublin Office: Spawth House, 52-54 Lower Spawth Street, Dublin 2, Ireland. Tel: 01 472 2200 Fax: 01 472 2184
London Office: 12 Mill Street, London SE1 2AY, United Kingdom. Tel: (0)44 (0)4 5413 2722
 Consulting Engineers, Civil, Structural, Project Management E-mail: info@bm.ie Web: www.bm.ie

Barrett Mundy Consulting Engineers, Civil, Structural, Project Management E-mail: info@bm.ie Web: www.bm.ie
The Institution of Structural Engineers **ACEI**

CLIENT: **DEVELOPMENT 8**

PROJECT TITLE: **CONCORDE RESIDENTIAL DEVELOPMENT** BM PROJECT NO: **18.232**

MODEL REFERENCE: **CCRD-BMD-00-ZZ-DR-C-1010** MODEL REV: **P1** SUBMITALTY: **S1**

DRAWING TITLE: **AUTOROUTE REFUSE VEHICLE TRACKING**

DRAWING NO: **CCRD-BMD-00-ZZ-DR-C-1050** ISSUE: **PL4**